



# REV-1250T6, 3/4" SUPER DUTY COMPOSITE IMPACT



**Rated Capacity : 3/4" Sq. Drive**

**Free Speed : 6000 R.P.M. ±10%**

**Air Inlet Size : 3/8"(NPT) internal thread**

**Min.Hose Size: 1/2"(13 mm)**

**Impact mechanism: Twin Hammer**

**Overall Length : 8.66"(220 mm)**

**Net Weight: 7.93 lbs (3.6 kg)**

**Output Torque:**

**Working Torque (at 5 sec): 1250 ft-lbs(1675 Nm)**

**Max. Torque (at 15 sec): 1350 ft-lbs (1809 Nm)**

**Features :**

★ **Composite Housing design for light weight**

★ **Forward / reverse power regulator with 3 forward power settings and one reverse setting for maximum power**



Twin hammer impact mechanism to perform best torque output, and Special Hardened-Treatment to maintain best durability.



Vane with spring mounted to prevent dead-lock or power-less problem.



Composite handle to provide best power-to-weight ratio, and prevent uncomfortable usage during the temperature change.

Special Hardened-Treated Cylinder, Front plate and Rear plate to generate best durability.

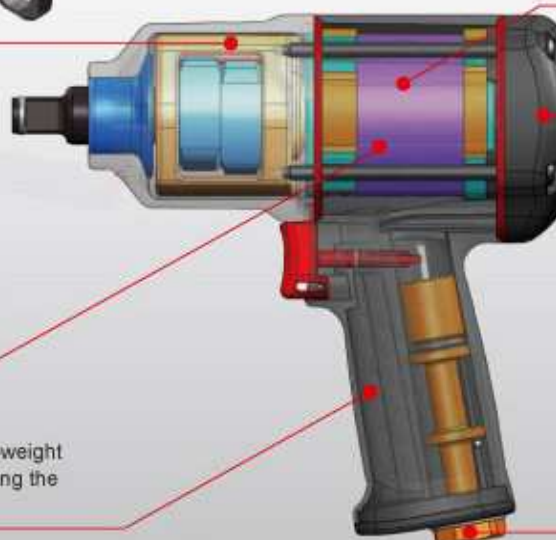

3 different speed adjustment at Forward direction.  
1 full speed at Reverse direction.



360 degree swivel air inlet to prevent air hose twisted.